

Material; 10 Ga. steel sheet.

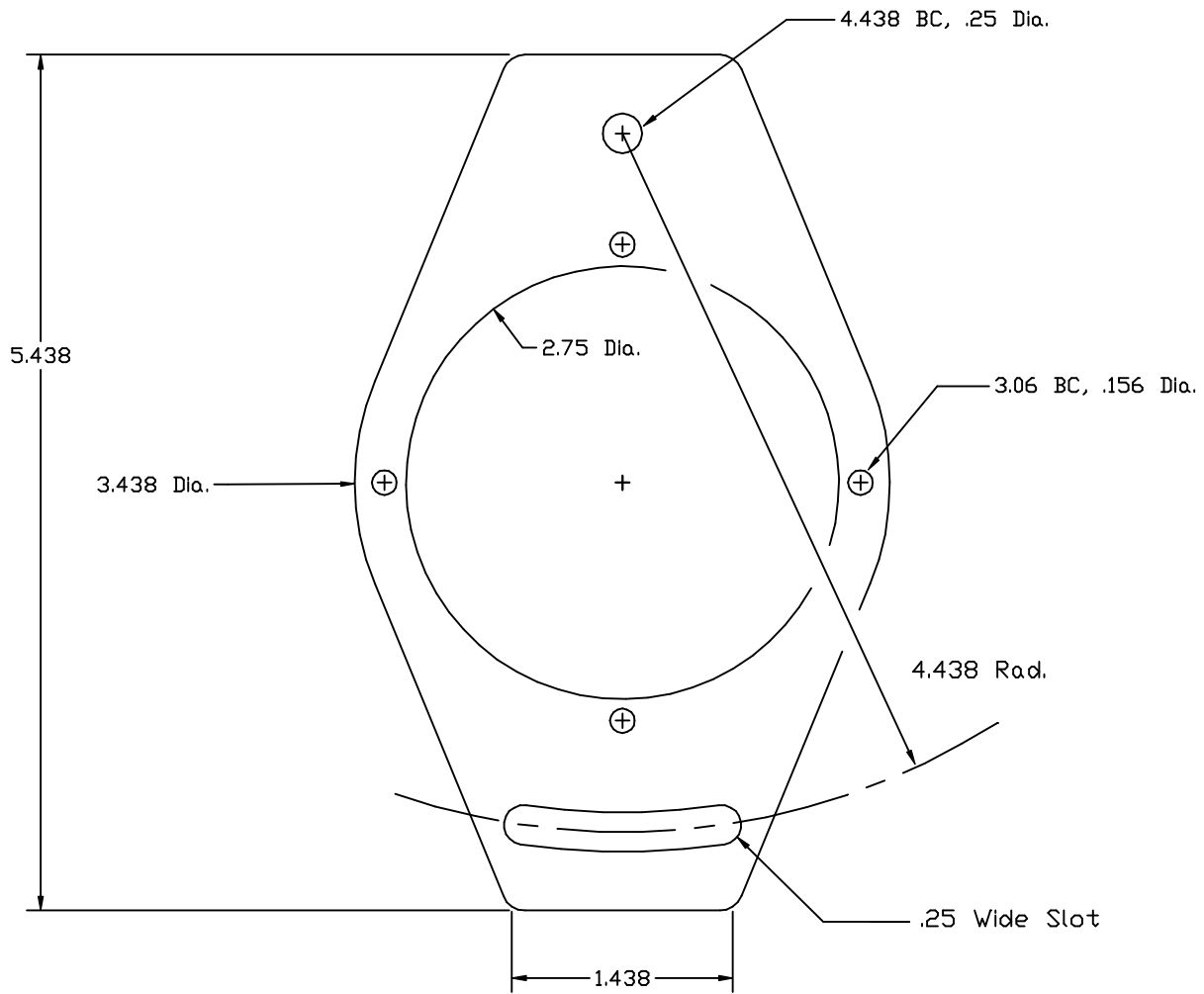

Material; Aluminum.

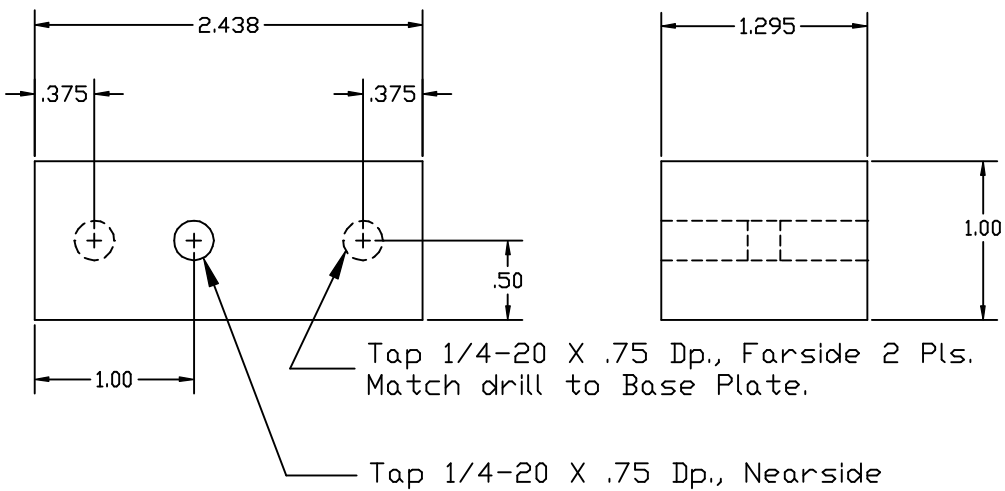

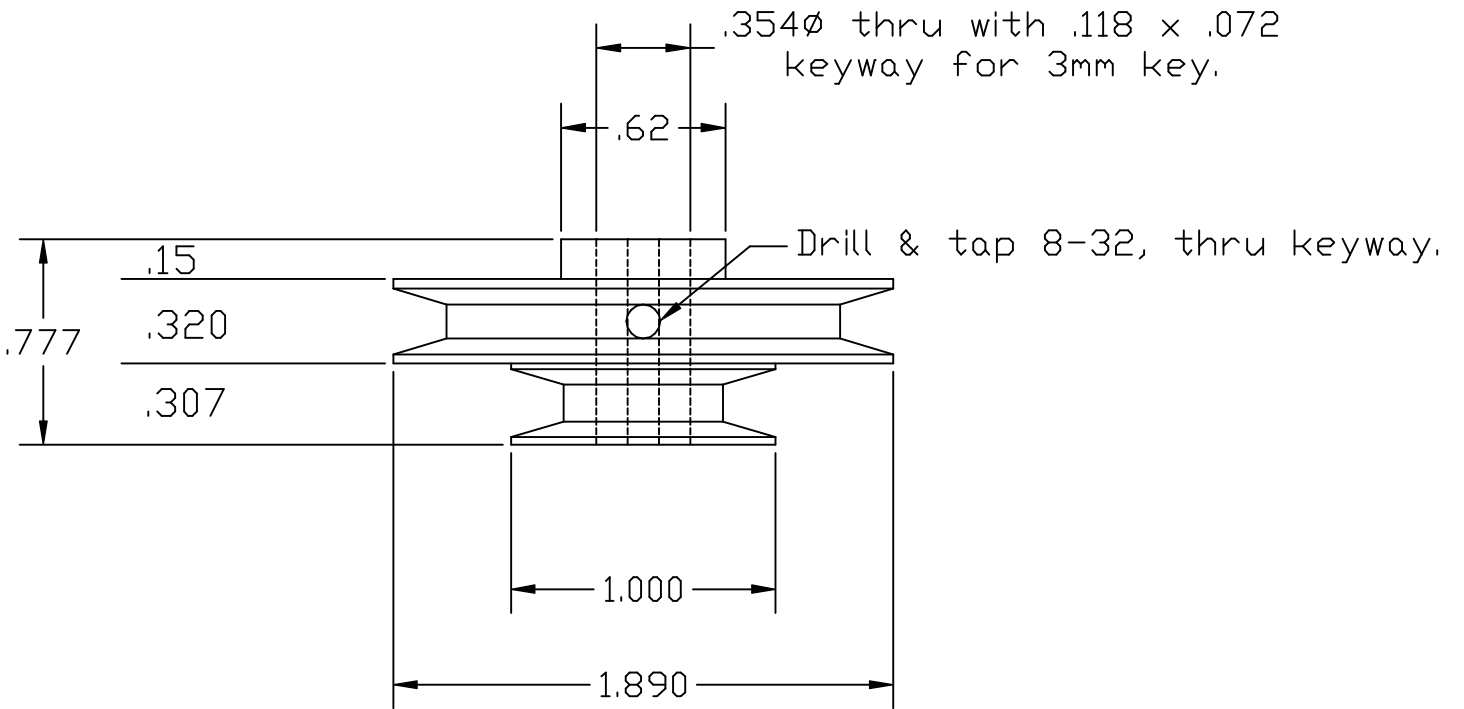
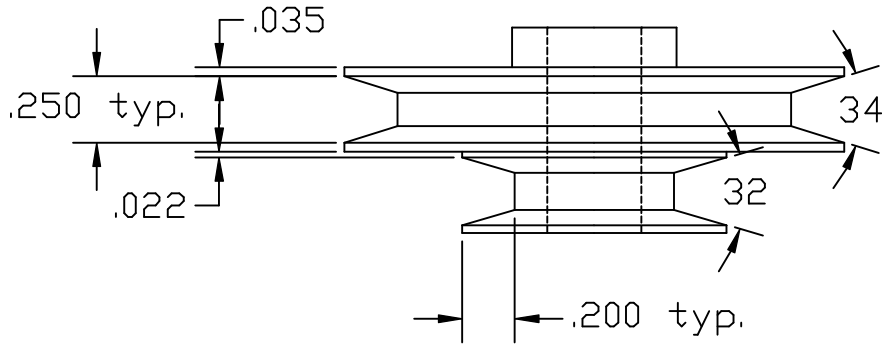

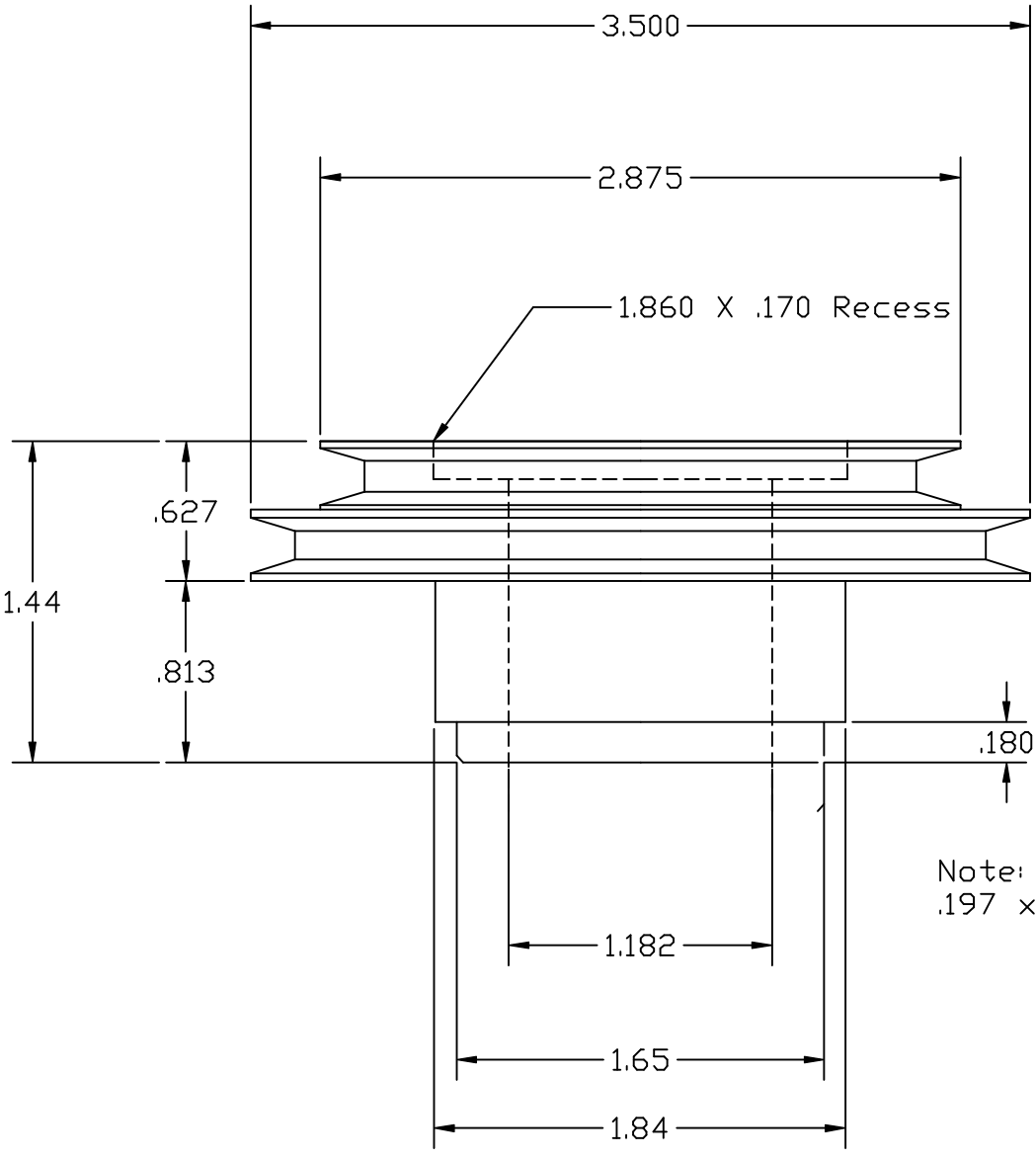
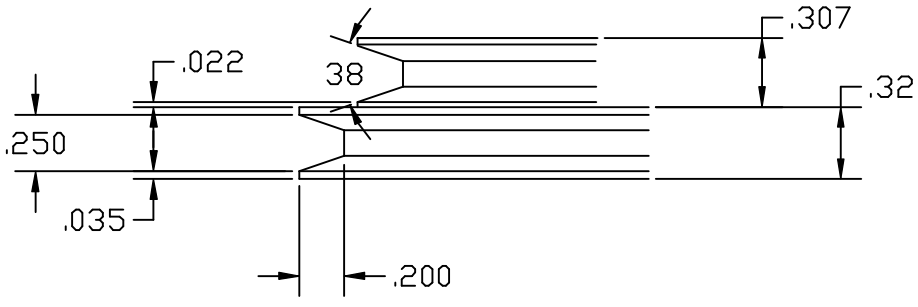

Note: 1.182 bore thru with .197 x .09 keyway for 5mm key.